

## CUTSHEET

Front View

Side View

Top View

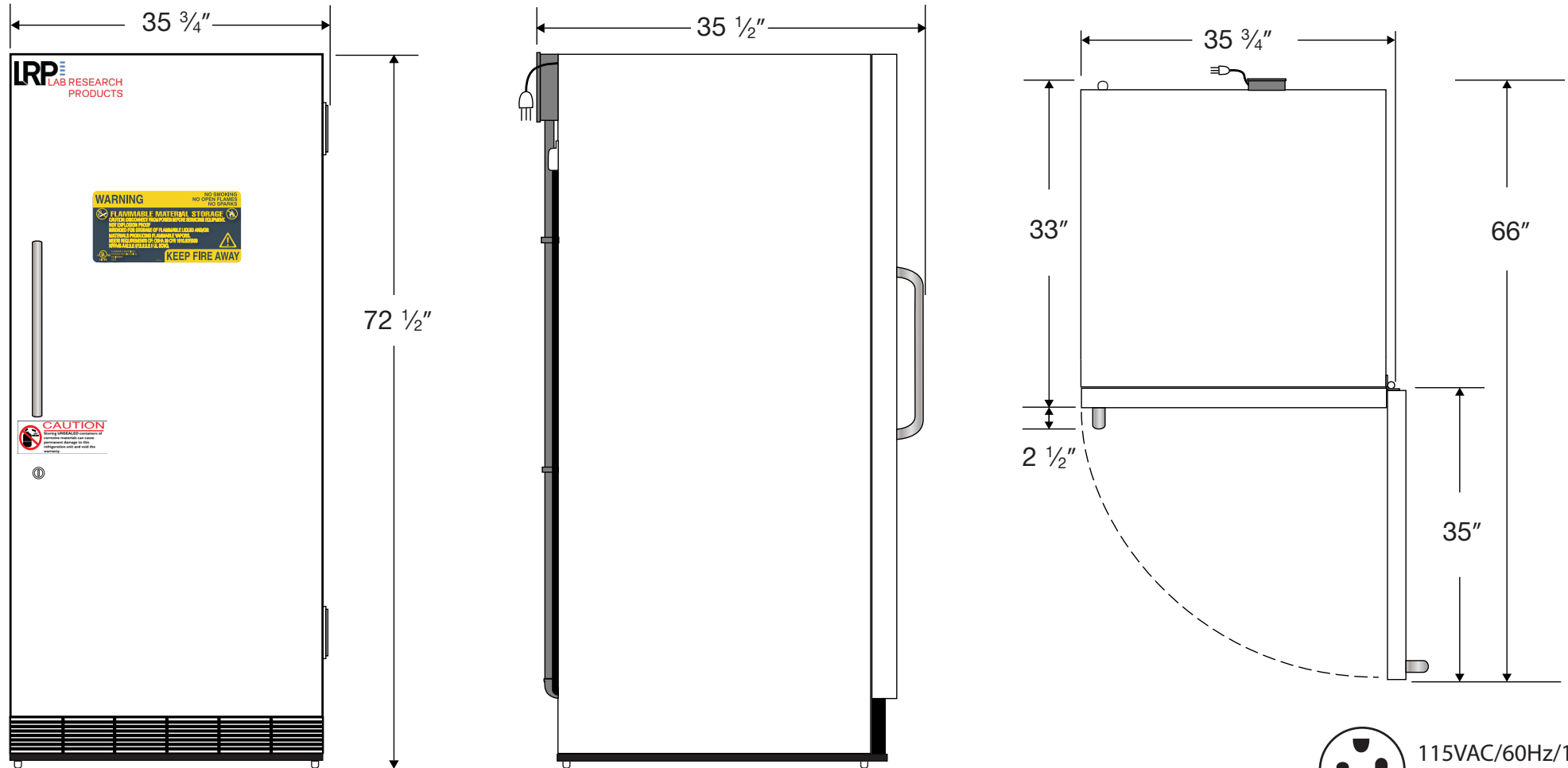

115VAC/60Hz/1PH  
NEMA-5-15P

Cu. Ft	Defrost	Door	Int Door	Shelves	W"	D"	H"	Refrigerant	H.P.	Amps	Weight
30	Manual	1 Solid	1 Freezer	3 Adj Refrigerator	$35 \frac{3}{4}$	$35 \frac{1}{2}$	$72 \frac{1}{2}$	R404a	$\frac{1}{3}$	6	336 lbs.