

LRP-HC-ERFC10

Images



Product Description

In the fast-paced world of scientific and industrial laboratories, precision and safety are key. Our Hazardous Location Combo Units are engineered for use in environments where volatile or explosive conditions could exist. Crafted with ATEX and non-sparking components, these units are designed to keep you and your substances safe. These units meet NFPA and OSHA guidelines for Hazardous Location, Class 1, Division II, Groups C & D guidelines. Engineered with a microprocessor temperature controller, these units provide exceptional precision, recovery, and maintenance. You'll also experience the power of natural hydrocarbon refrigerants through energy savings and a greener laboratory footprint—all while enjoying stellar system performance. *

*Note: Please be aware that these units come without a plug and require hardwiring in conduit, ensuring a secure connection in your high-risk environment. Our freestanding models also require 4 inches of clearance for proper ventilation and safety.

General Description and Application

Storage capacity (cu. ft)	9 Cu. Ft.
Door	Two swing solid doors
Shelves	3 adjustable (refrigerator) and 2 fixed (freezer)
Freezer Compartments	1
Baskets	3 Removable (freezer)
Mounting	Leveling legs and stacking kit
Interior lighting	Non-applicable
Airflow management	Non-applicable
External probe access	Non-applicable
Insulation	Cabinet is foamed-in-place with EPA compliant high density urethane foam
Exterior materials	White powder coated steel
Access Control	Keyed door locks
General warranty	Two (2) year parts and labor warranty
Product Weight (lbs)	175
Shipping Weight (lbs)	205
Rated Amperage	1.2 (refrigerator) 1.4 (freezer) Amps
Power Plug/Power Cord	Exposed flying leads, 3 wires
Facility Electrical Requirement	115VAC/60Hz/1PH
Agency Listing and Certification	ETL Listed, Units meet NFPA guidelines 45 and 70

Refrigeration System

Refrigerant	R600a
Defrost	Cycle (Refrigerator) and Manual (Freezer)

Controller, Configuration, Alarms and Monitoring

Controller technology	Microprocessor Temperature Controller
Display technology	Digital temperature display
Adjustable Temperature Range (Refrigerator)	1°C to 10°C
Adjustable Temperature Range (Freezer)	-15°C to -25°C
External alarm connection	Remote alarm contacts, refrigerator and freezer
Alarms	Audible and visual high and low temperature alarms, refrigerator and freezer
Simulator Ballast	Glass beads in a bottle
Digital Communication	Non-applicable
Data Transfer	Non-applicable
Disclaimers	This unit must have 4" clearance on sides and back for adequate ventilation

Dimensions

	Width (in.)	Depth (in.)	Height (in.)	Door Swing (in.)	Total open Depth (in.)
Exterior	23 5/8"	23 5/8"	65"	22"	45 5/8"
Interior	Top 20 1/4" - Bottom 19"	Top 17" Bottom 16"	51 5/8"		

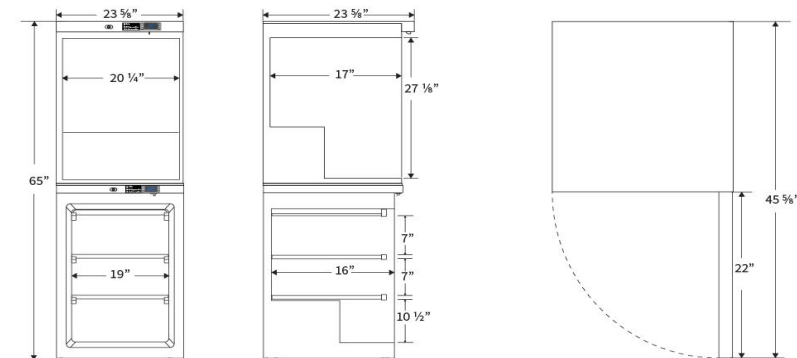

Contact

Customer Service 800-648-4041 Option 3
 Technical Service 800-648-4041 Option 5, Parts Option 4
Rev. 01232024

customerservice@horizonscientific.com
technicalservice@horizonscientific.com