

Front View

Side View

Top View

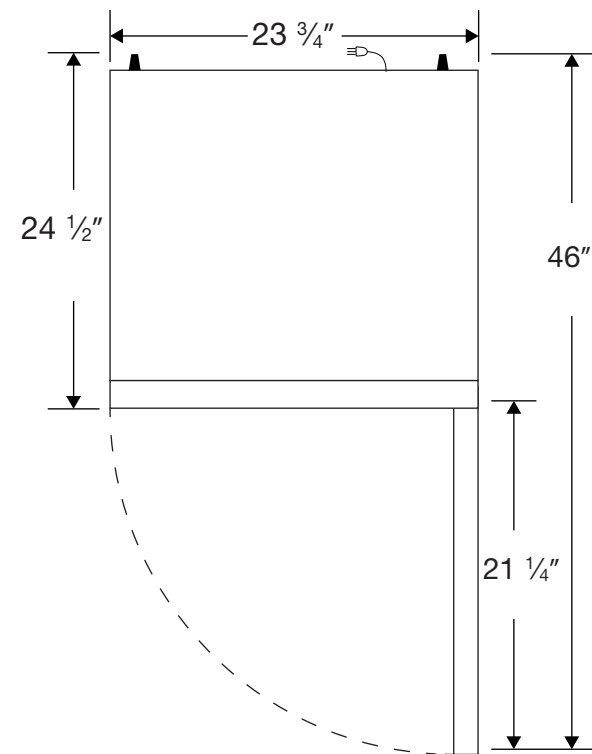
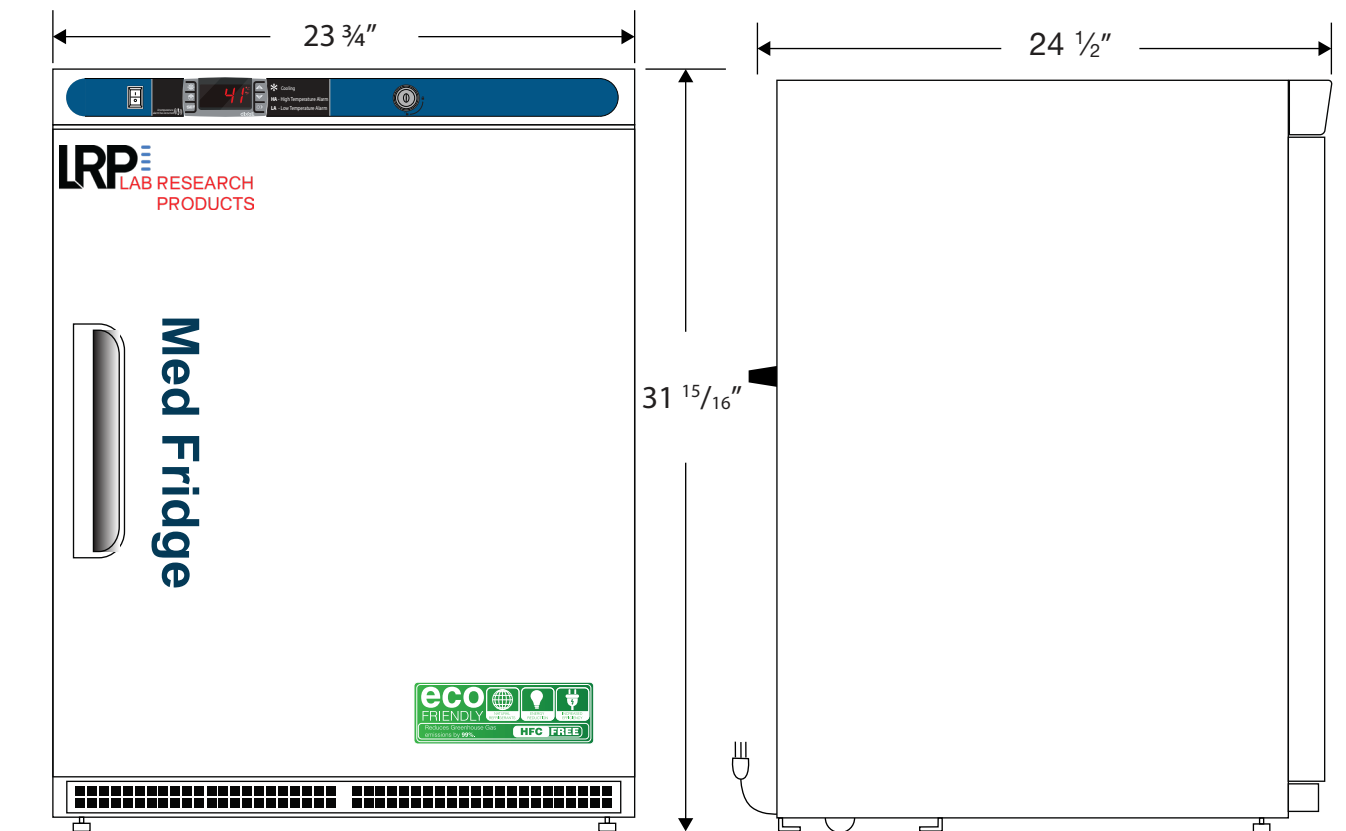

32" HEIGHT MEETS ADA GUIDELINES



115VAC/60Hz/1PH
NEMA-5-15P

Cu. Ft	Defrost	Door	Int Door	Shelves	W"	D"	H"	Refrigerant	H.P.	Amps	Weight
4.6	Cycle	1 Solid	0	2Adj/1 Fixed	23 ³ / ₄	24 ¹ / ₂	31 ¹⁵ / ₁₆	R600a	¹ / ₈	1.74	97 lbs.