

LRP-HC-EFS-30

Product Description

This hazardous location freezer meets NFPA and OSHA guidelines for the safe storage of materials in potentially hazardous work environments. This model is the ideal choice for industrial environments requiring strict safety protocols. It delivers 30 cubic feet of spacious storage and utilizes EPA SNAP compliant natural refrigerants for environmentally responsible operation. Powered by microprocessor temperature technology, this model delivers precise and stable temperature control. Please note that this unit must be hardwired for safety. With low energy consumption and high safety standards, this model is a safe and efficient solution for hazardous laboratory locations and industrial settings.

Images



Certifications



General Description and Application

Storage capacity (cu. ft)	30 Cu. Ft.
Door	One (1) solid swing, right hinged; stainless steel door handle; magnetic door gasket
Shelves	Four (4) fixed evaporator shelves
Mounting and Installation	Leveling legs
External probe access	3/4" probe access port on rear wall
Insulation	EPA compliant high density urethane foam
Exterior materials	Powder coated steel
Access control	Keyed door lock
General warranty	Two (2) year parts and labor warranty
Compressor warranty	Five (5) year compressor parts warranty
Product Weight (lbs)	300
Shipping Weight (lbs)	330
Rated Amperage	3.3 Amps
Power Plug/Power Cord	Power cord not included, final power connections must be hardwired to meet local codes
Facility Electrical Requirement	110 - 120V AC, 15A breaker, NEMA 5-15 receptacle
Agency Listing and Certification	UL listed per UL 60335-1 and UL 60335-2-89 standards; c UL listed per CSA C22.2 Meet NFPA and OSHA guidelines for hazardous locations, Class 1 Division II, Groups C & D

Performance

Uniformity (Cabinet air)	+/- 3°C
Stability (Cabinet air)	+/- 4°C
Maximum temperature variation (Cabinet air)	8°C Total
Energy Consumption (kWh/day)	5.0 kWh/day
Average Heat Rejection (BTU/hr)	705 BTU/hr
Pull down time to nominal operating temp	70 min (empty)

Refrigeration System	
Compressor	Hermetic, variable speed
Refrigerant	EPA SNAP compliant R290 propane
Condenser	Static - exterior walls of cabinet with auxiliary fan
Evaporator	Evaporator shelves
Defrost	Manual defrost

Controller, Configuration, Alarms and Monitoring	
Controller technology	Microprocessor temperature controller with variable frequency compressor control
Display Technology	Digital temperature display, sample simulated digital temperature display; .1° resolution
Adjustable Temperature Range	-15° C to -25° C
External alarm connection	Remote alarm contacts
Alarms	Audible and visual high/low-temperature alarms, remote alarm contacts
Display Probe	Product simulator bottle with glass bead media

Disclaimers

Defrosting of the unit will need to be performed periodically to prevent severe ice build-up.
 Indoor use only, +18° C to +26° C (+65° F to +78° F), <70% RH
 Specifications are subject to change.
 Equipment requires 4" of clearance around back and sides of the unit for proper ventilation – improper installation will void the warranty and will lead to temperature maintenance issues, overheating and possible failure.
 Performance claims are based on testing at 22°C ambient using unbuffered air temperatures in an empty freezer at steady state operation.
 Performance may vary with environmental conditions, product load, or door openings.

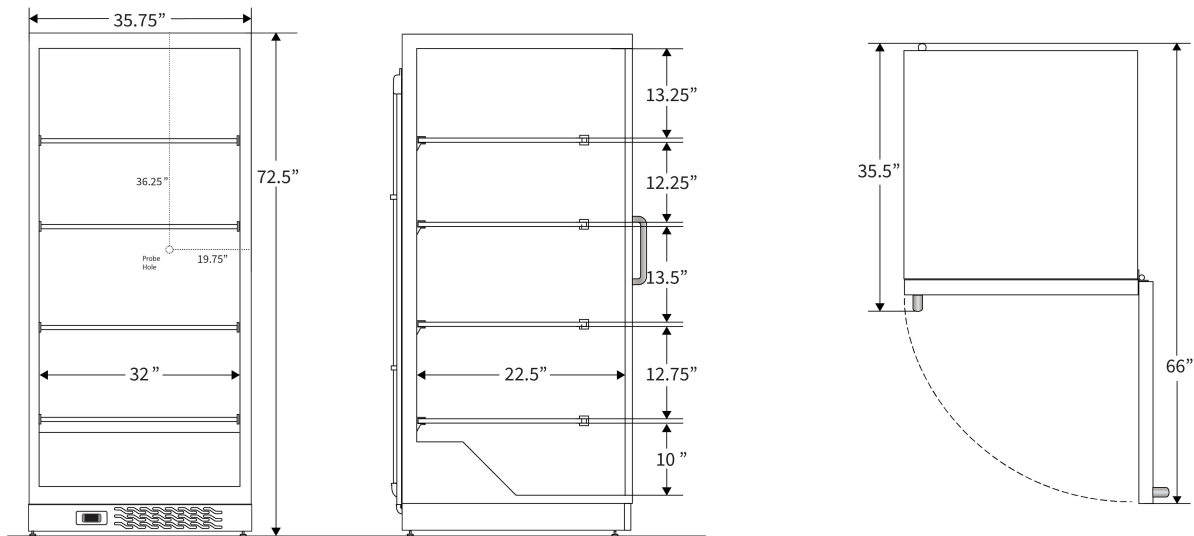

Contact		
Customer Service	800-648-4041 Option 3	customerservice@horizonscientific.com
Technical Service	800-648-4041 Option 5, Parts Option 4	technicalservice@horizonscientific.com