

## LRP-VS-LS-72

### Product Description

These Basic Series laboratory refrigerators are designed for reliable and cost-effective cold storage. This model features ultra-low energy consumption and energy efficient natural refrigerants. Using microprocessor temperature technology, this unit delivers precise temperature monitoring and control. It offers essential security features, including keyed door locks and temperature alarms, along with remote alarm contacts. Enjoy durable powder-coated steel construction, glass door transparency, and adjustable inner shelving to optimize your workflow. All features are designed to heighten performance and efficiency in your lab.

### Images



### Certifications



### General Description and Application

Storage capacity (cu. ft)	72 Cu. Ft.
Door	Three (3) swing glass doors, self-closing, magnetic door gasket
Shelves	Twelve (12) adjustable shelves (adjustable in 1/2" increments)
Mounting and Installation	Swivel casters - locking front casters
Interior lighting	LED interior lights are safety shielded and switch controlled
Airflow Management	Non-applicable
External probe access	3/4" probe access port on rear wall
Insulation	Cabinet is foamed-in-place with EPA compliant high-density urethane foam
Exterior materials	White powder coated steel
Access control	Keyed door locks
General warranty	Two (2) year parts and labor warranty
Compressor warranty	Five (5) year compressor warranty
Product Weight (lbs)	618
Shipping Weight (lbs)	741
Rated Amperage	3 Amps
Power Plug/Power Cord	NEMA 5-15 plug
Facility Electrical Requirement	110 - 120V AC, 15A breaker, NEMA 5-15 receptacle
Agency Listing and Certification	ETL, C-ETL listed. Meets or exceeds ENERGY STAR® v2.0 for Laboratory Refrigerators. Official listing pending - see energystar.gov

### Performance

Maximum temperature variation (Cabinet air)	+/- 2.5° C
Stability (Simulator ballast)	+/- 0.5° C
Adjustable Temperature Range	2°C to 15°C
Stability (Simulator bag)	Non-applicable
Energy Consumption (KWh/day)	<2.8 KWh/day *meets ENERGY STAR® v2.0 for Laboratory Refrigerators
Average Heat Rejection (BTU/hr)	<720 BTU/h
Noise Pressure Level (dBA)	40 dBA or less installed
Pull down time to nominal operating temp	< 60 min (empty)

### Performance Note

Max temperature variation based on an empty chamber at steady state using 15 bare (unweighted) thermocouple probes. Product loading, door openings, and ambient conditions will affect performance. Stability of simulator ballast based on bottle probe provided with the unit located center of empty chamber at steady state, no door openings

Refrigeration System	
Compressor	Hermetic
Refrigerant	EPA SNAP compliant R600a Isobutane (Hydrocarbon natural refrigerant)
Condenser	Tube and grid, high efficiency fan forced air
Evaporator	Fin and tube, high efficiency fan forced air
Defrost	Cycle Defrost

Controller, Configuration, Alarms and Monitoring	
Controller technology	Microprocessor temperature controller, C°/F° switchable, resolution is 0.1° C/0.2° F
Battery Backup	Non-applicable
Display technology	Non-applicable
Display probe	Product simulator bottle with glass bead media
External alarm connection	Remote alarm contacts
Alarms	Audible and visual high/low temperature alarms, remote alarm contacts
Disclaimers	Refrigerator requires a minimum 2" of clearance around back and sides of the unit for proper ventilation (more if next to heat rejecting equipment) - improper installation will void the warranty and will lead to temperature maintenance issues, overheating and possible failure

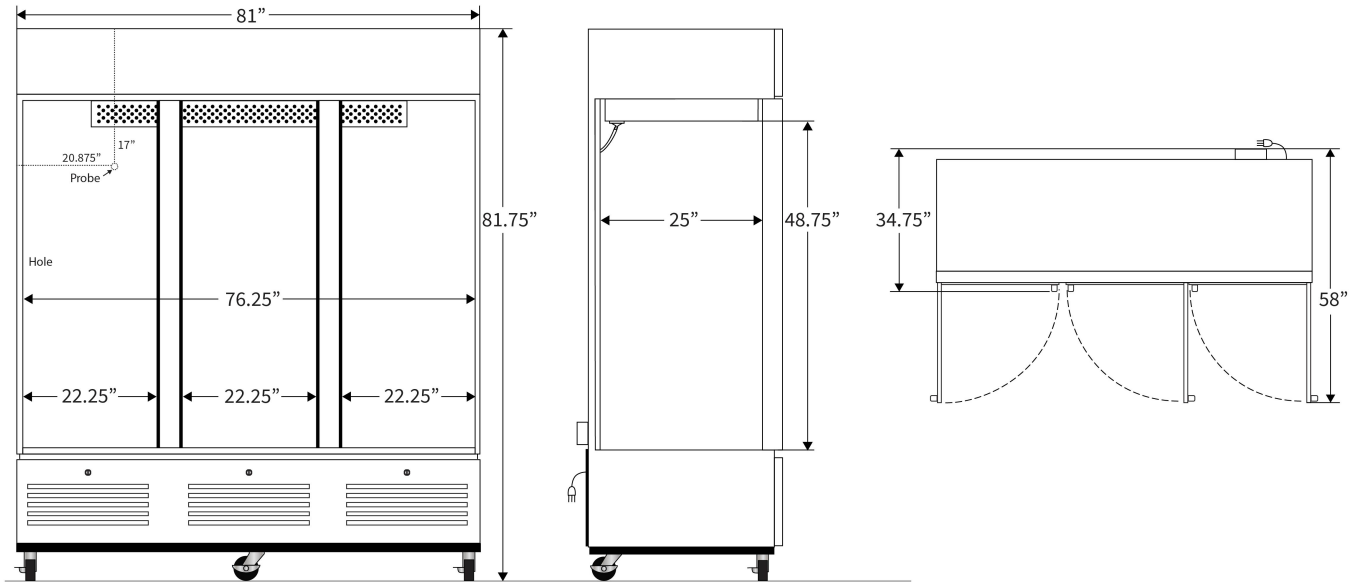

Contact		
Customer Service	800-648-4041 Option 3	<a href="mailto:customerservice@horizonscientific.com">customerservice@horizonscientific.com</a>
Technical Service	800-648-4041 Option 5, Parts Option 4	<a href="mailto:technicalservice@horizonscientific.com">technicalservice@horizonscientific.com</a>