

LRP-HC-FRCS-30

Product Description

This standard flammable storage refrigerator/freezer combination unit offers a secure solution for storing volatile materials in laboratory and industrial settings. This model meets NFPA and OSHA guidelines 45 and 70 for the refrigerated storage of flammable (volatile) materials in general laboratory work areas. Its temperature control is powered by microprocessor technology for improved temperature precision and uniformity. A series of audible and visual alarms safeguards stored contents for added protection. Utilizing hydrocarbon refrigerants, this unit also meets EPA SNAP compliance, protecting environmental safety. With low energy consumption and high safety standards, this model is an efficient and dependable solution for the safe storage of flammable substances.

Images



Certifications



General Description and Application

Storage capacity (cu. ft)	30 Cu. Ft. (25 Cu. Ft. Refrigerator/5 Cu. Ft. Freezer)
Door	One (1) solid swing, right hinged; stainless steel door handle; magnetic door gasket
Interior	One (1) inner door (Freezer)
Shelves	Three (3) adjustable wire shelves (Refrigerator)
Mounting and Installation	Leveling legs
External probe access	Two (2) 3/4" probe access ports on rear wall
Insulation	EPA compliant high density urethane foam
Exterior materials	Powder coated steel
Access control	Keyed door lock
General warranty	Two (2) year parts and labor warranty
Compressor warranty	Five (5) year compressor parts warranty
Product Weight (lbs)	353
Shipping Weight (lbs)	383
Rated Amperage	3 Amps
Power Plug/Power Cord	NEMA 5-15P plug, 6 ft long cord
Facility Electrical Requirement	110 - 120V AC, 15A breaker, NEMA 5-15 receptacle
Agency Listing and Certification	UL listed per UL 60335-1 and UL 60335-2-89 standards; c UL listed per CSA C22.2 No. 120 standard, in compliance with the requirements for Flammable Materials Storage Refrigerators as defined by NFPA 99 and 45

Performance

Freezer Maximum temperature variation	+/- 4.5°C
Refrigerator Maximum temperature variation	+/- 2.5°C
Freezer temperature range	-15°C to -20°C
Refrigerator temperature range	0°C to 8°C
Pull down time to nominal operating temp	90 min (empty)
Energy Consumption (kWh/day)	4 kWh/day
Average Heat Rejection (BTU/hr)	570 BTU/hr

Refrigeration System	
Compressor	Hermetic, variable speed
Refrigerant	EPA SNAP compliant R290 propane
Condenser	Static - exterior walls of cabinet with auxiliary fan
Evaporator	Evaporator shelves
Defrost	Manual defrost
Controller, Configuration, Alarms and Monitoring	
Controller technology	Microprocessor temperature controller with variable frequency compressor control
Battery Backup	Non-applicable
External alarm connection	Remote alarm contacts
Alarms	Audible and visual high/low-temperature alarms, door ajar alarm, remote alarm contacts
Disclaimers	
<p>Defrosting of the unit will need to be performed periodically to prevent severe ice build-up and to ensure proper temperature control. Refrigerator temperatures are impacted by the freezer temperature, especially at coldest freezer settings.</p> <p>Indoor use only, +18° C to +26° C (+65° F to +78° F), <70% RH</p> <p>Specifications are subject to change.</p> <p>Equipment requires 4" of clearance around back and sides of the unit for proper ventilation – improper installation will void the warranty and will lead to temperature maintenance issues, overheating and possible failure.</p>	

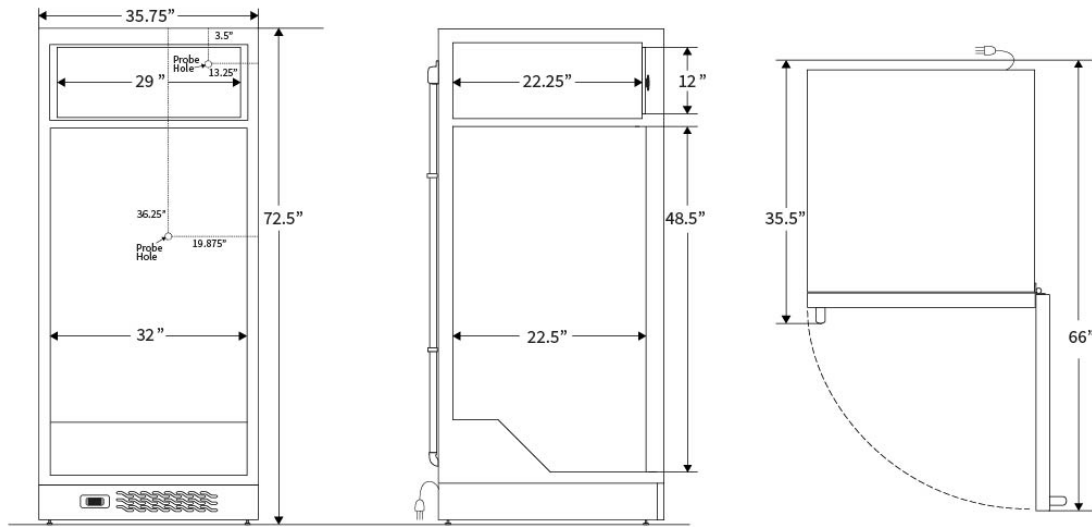

Contact		
Customer Service	800-648-4041 Option 3	customerservice@horizonscientific.com
Technical Service	800-648-4041 Option 5, Parts Option 4	technicalservice@horizonscientific.com

