

This ULT Benchtop Freezer delivers reliable ultra-low temperature performance in a compact design. Engineered with Stirling engine technology and helium refrigerant, this unit provides efficient cooling down to -86°C while maintaining low energy consumption and quiet operation. Designed for bench top convenience, the freezer features a top-access swing door with a compression latch closure and a keyed lock for safety. This compact ULT is ideal for specialty applications where dependable -86°C storage is required without the footprint of a full-size ULT freezer.

LRP-ULT-BT-86

General Description and Application

Storage capacity:	5.25" x 5.25" x 3" cryogenic sample storage box
Door:	Top access swing door, compression latch closure
Freezer Compartment	One, top access
Mounting and Installation	Rubber feet
Interior lighting:	Non-applicable
Airflow management:	Non-applicable
External probe access:	Non-applicable
Insulation:	Enclosure is foamed-in-place with EPA compliant high density urethane foam and VIPs
Exterior materials:	White powder coated steel
Access control:	Keyed door lock
General warranty:	Two (2) years parts and labor warranty
Compressor warranty:	Non-applicable
Product weight (lbs):	21
Shipping weight (lbs):	40
Exterior width (in):	10.25"
Exterior depth (in):	11"
Exterior height (in):	18.5"
Rated Amperage:	AC: 1 Amp DC: 10 Amps
Power Plug/Power Cord:	AC: NEMA 1-15P plug DC: 12V automotive socket
Facility Electrical Requirement:	AC: 110-127V, 15A, NEMA 5-15 receptacle DC: 12V, 15A fuse, automotive socket
Agency Listing and Certification:	cETLus, CE, FC, RoHS, UK CA. 24V DC system operating voltage

Refrigeration System

Compressor	Stirling engine
Refrigerant	Helium
Condenser	Integral heatsink
Evaporator	Integral cold plate
Defrost	Manual defrost

Performance

Energy Consumption (kWh/day)	< 1.10 kWh/day
Average Heat Rejection (kWh/day)	< 1.33 kWh/day
Average Heat Rejection (BTU/hr)	< 190 BTU/hr
Noise pressure level (dBA)	45 dBA or less installed
Pull down time to nominal operating temp:	< 210 min to -86C (empty)

Controller, Configuration, Alarms and Monitoring

Controller technology	Microprocessor with capacitance touch display
Battery Backup	Adapter included for 12V socket power
Temperature setpoint range	40°C to -86°C
Display probe	Integral RTD probe
External alarm connection	Non-applicable
Alarms	Audible & Visual Alarms when the temperature is above the set point by 10°C for 5 minutes
Simulator ballast	Display simulates the air temperature in the geometric center of the chamber as measured in an empty chamber

Notes on Performance Data:

Temperature readout is based on an empty chamber at steady state using a bare (unweighted) thermocouple probe in the geometric center. Product loading, door openings, and ambient conditions will affect performance.

Disclaimer:

The freezer requires a minimum 2" of clearance at back and sides of the unit for proper ventilation

Certifications



Chart Images

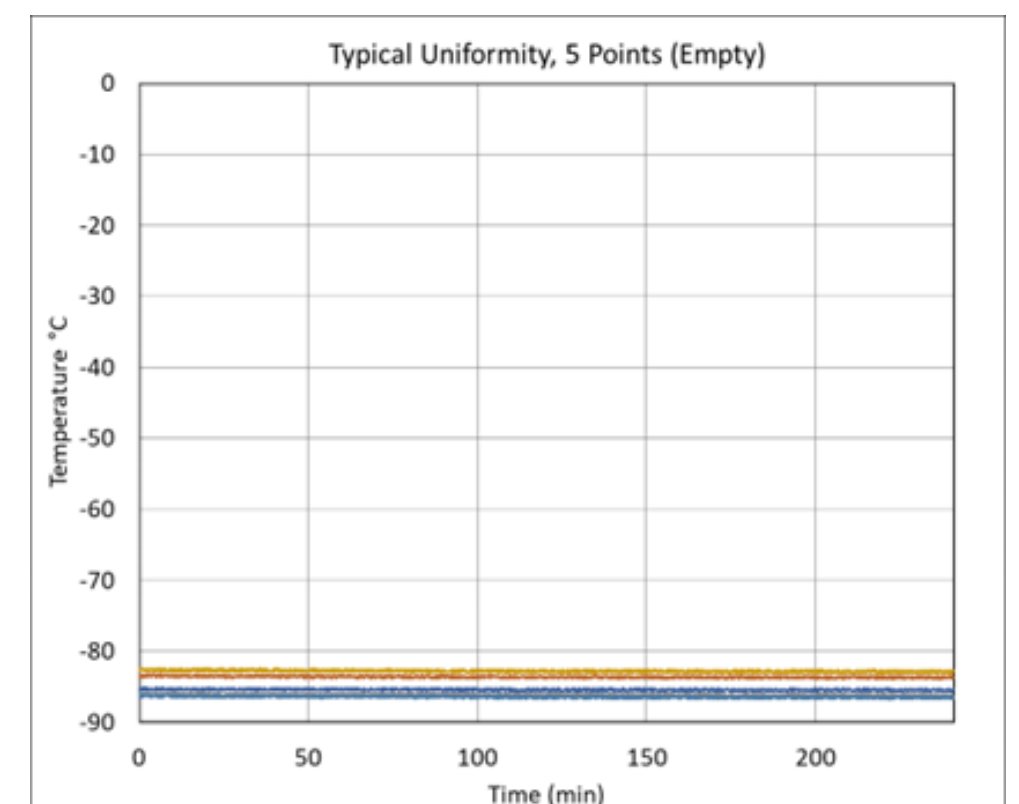
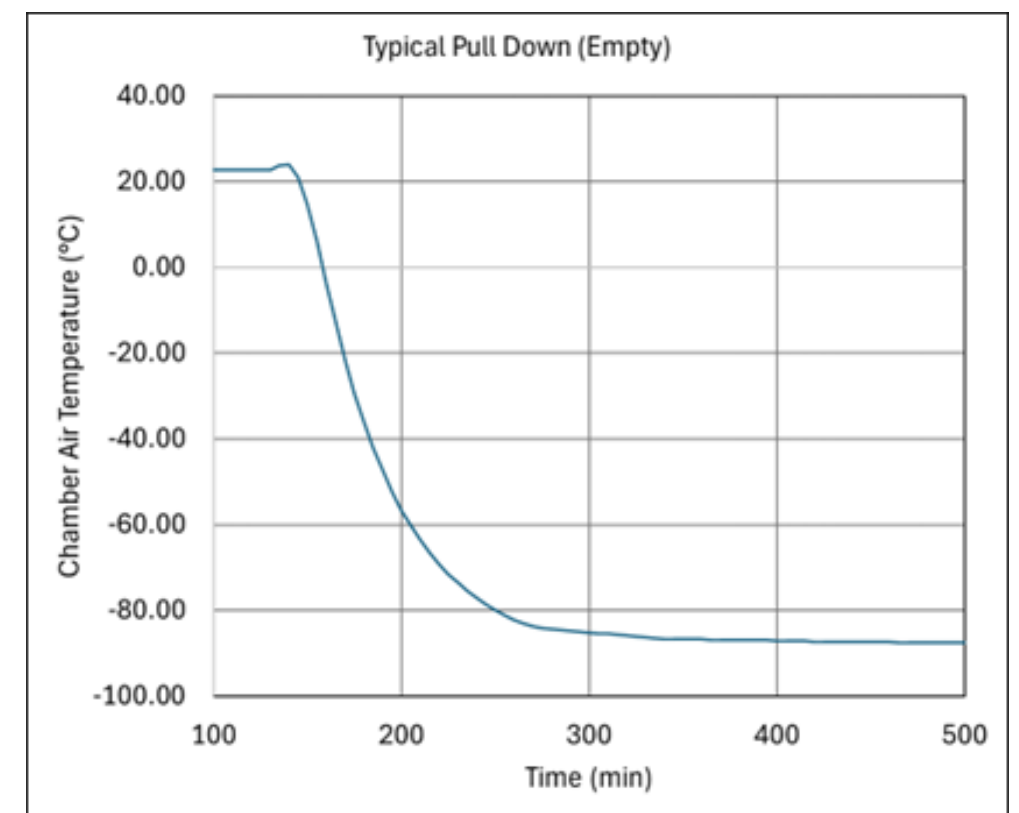

Images

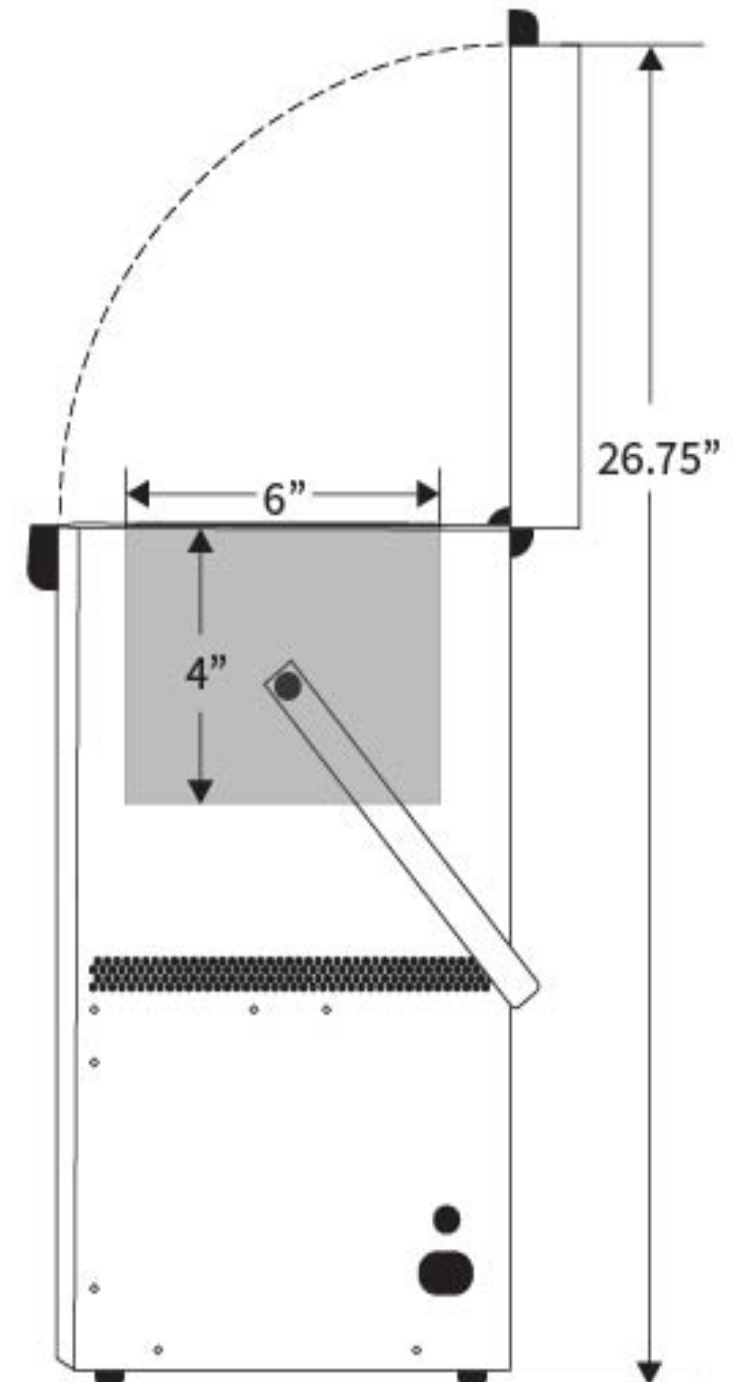
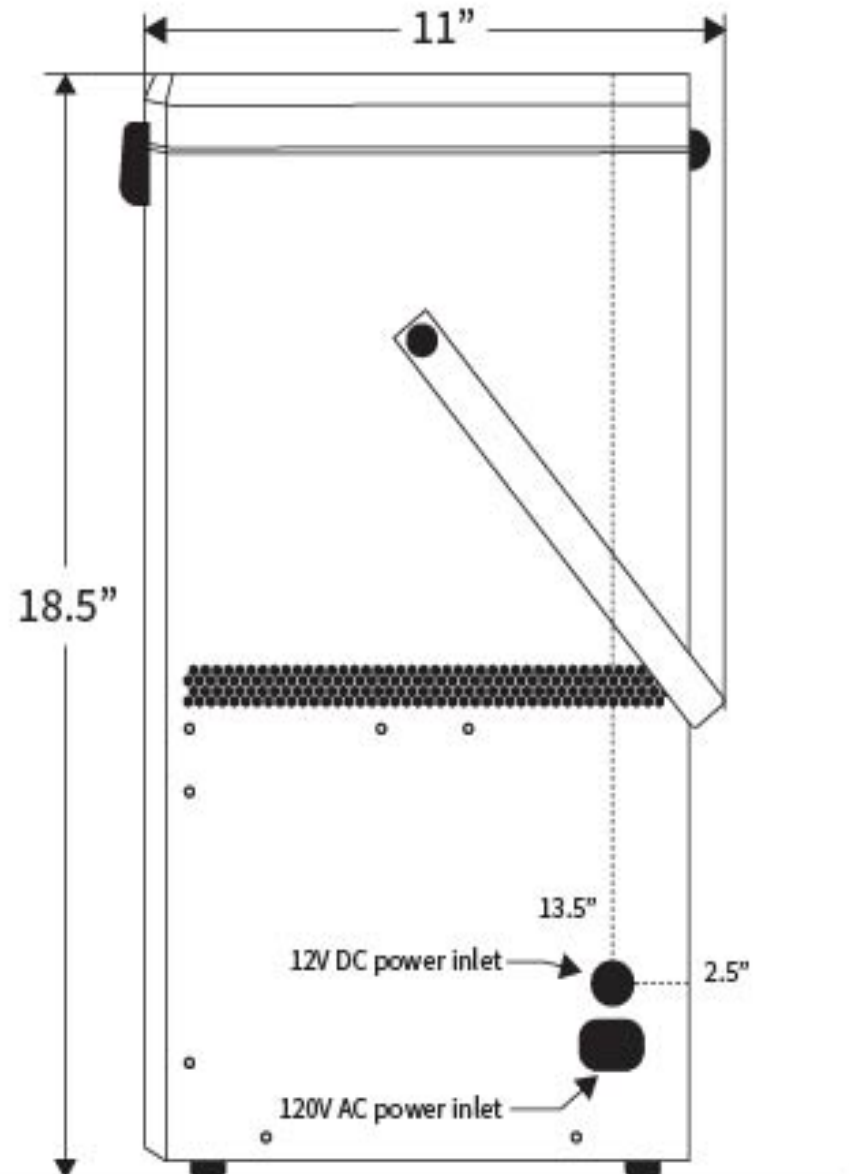
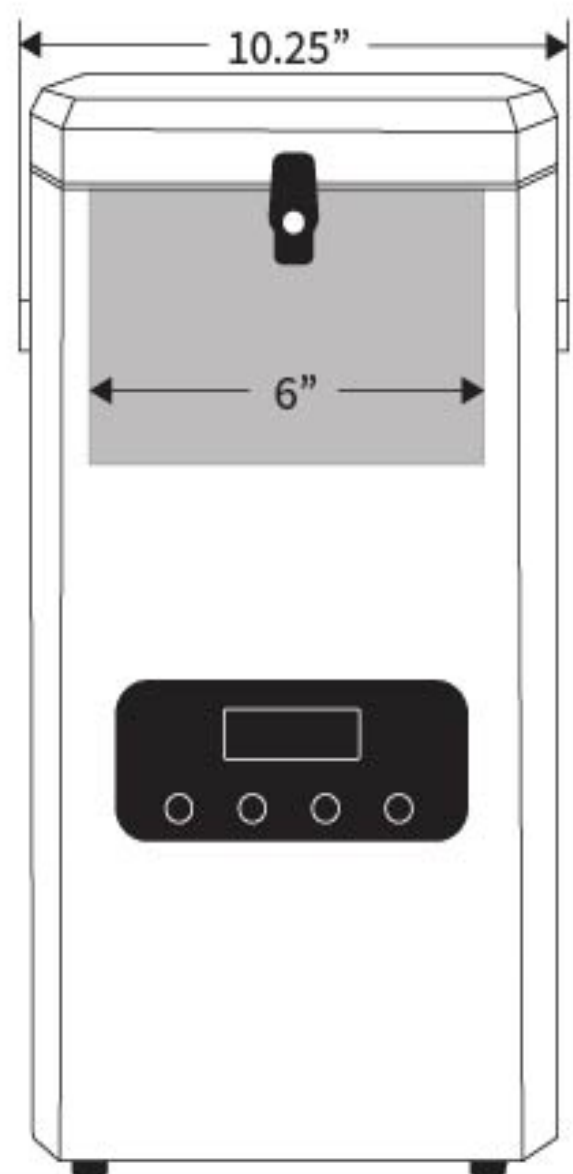

Contact

Customer Service
Technical Service

800-648-4041 Option 3
800-648-4041 Option 5, Parts Option 4

customerservice@horizonscientific.com
technicalservice@horizonscientific.com