

Front View

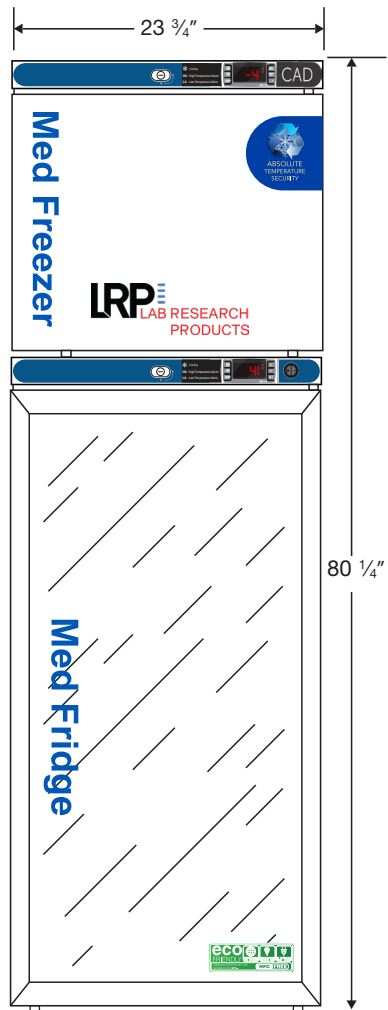

Side View

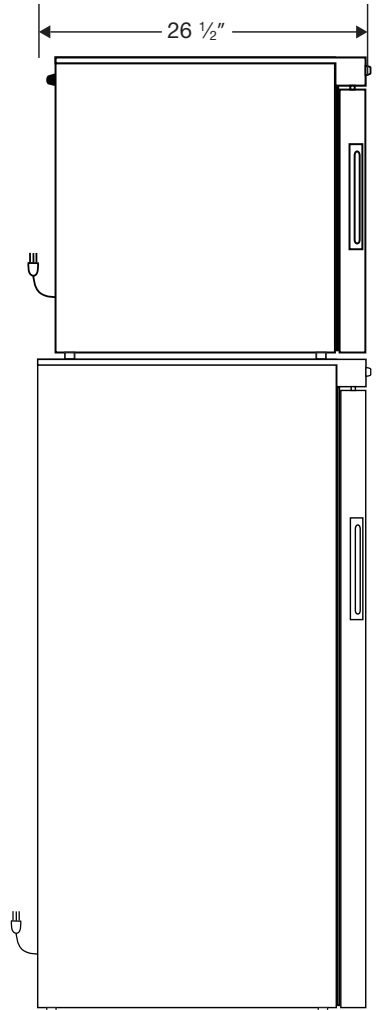

Top View

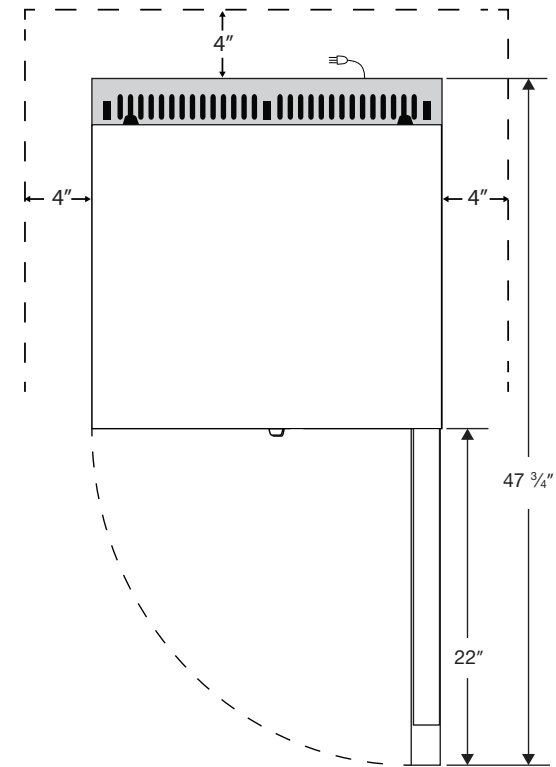

NOTE: Ventilation Requirements – Minimum 4" clearance on sides and back



115VAC/60Hz/1PH
NEMA-5-15P

Compartment	Cu. Ft	Defrost	Door	Int Door	Shelves	W"	D"	H"	Refrigerant	H.P.	Amps	Weight
Freezer	1	Controlled Auto	1 Solid	0	2 Adj.	23 3/4	26 1/2	80 1/4	R600a	1/8	1	246 lbs.
Refrigerator	10.5	Cycle	1 Glass	0	6 Adj.					1/3	2.3	